

Accelerometer's for Wind Turbines

Alternative Energy

Wind turbines are a growing source of alternative clean energy sources. As individual machines, or combined as multiple machines to form wind farms, they are a growing presence in today's world and energy needs.

A wind turbine that converts the wind's mechanical energy into electrical energy is known as a wind generator. The size of wind generators can range from 500 kW to 6 MW. The most popular styles of wind generators are horizontal axis wind turbines. They have either 3 blades, and point upwind of the tower requiring rotational (yaw) control, or they have 2 blades, and point down wind of the tower naturally rotating with the wind. Occasionally you find a vertical axis wind turbine, also known as a Darrieus wind turbine, named after the French inventor. This "eggbeater" design is not popular, and has been overwhelmed by the performance of horizontal axis wind turbines.

Wind turbines have many things in common with low speed motor driven fans, like cooling towers. Instead of motors driven by electrical mains, providing mechanical energy to multiple reduction gearboxes, driving large low speed fan applications, the wind turbine is a large low speed fan, providing mechanical energy to multiple speed increasing gearboxes, driving a generator to produce electrical mains power. This process reversal has many rotating elements

that cause vibration and over time, with wear and tear, will eventually fail.

- The repairs can be very expensive
- The work height prohibitive
- The loss of electrical production costly.

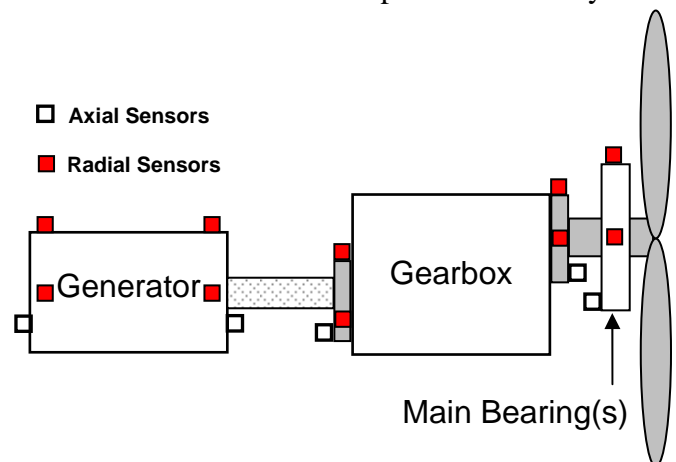

Horizontal Axis Turbine with Accelerometers

Low Frequency Accelerometers

The main bearing(s) and rotor shaft turn at less than 30 rpm. This would also be the turning speed of the input shaft for the gearbox. With a rotational frequency less than 30 cpm (0.5 Hz), low frequency accelerometers should be used. This will allow measurement of the main shaft rotational frequency, blade pass frequency, main bearing frequencies, and gearbox input shaft bearing frequencies and gear mesh frequencies.

These low frequency accelerometers typically provide 500 mV/g and a frequency span of 12 – 180,000 cpm (0.2 – 3000 Hz).



Low Frequency Accelerometers



Low Frequency Accelerometer Mounted in Horizontal Axis on Main Bearing

General Purpose Accelerometers

The intermediate shaft and output shaft of the gear box will have higher rotational speeds and generate higher frequency disturbances relative to the bearings and gear mesh. The output of the gearbox will typically be rotating 50 – 60 times faster than the input shaft. As a result of these

increased rotation speeds for the gearbox and generator, a general purpose accelerometer will work. General purpose accelerometers typically provide 100 mV/g and a frequency span of 30 – 900,000 cpm (0.5 – 15,000 Hz).



Axial & Vertical General Purpose Accelerometers Stud Mounted on Gear Box



General Purpose Accelerometers

Stud Mounting Accelerometers

The wind turbine is sitting on the top of a very high tower. The rotational components are not easy to access, and every effort should be made to stud mount the accelerometers. Mounting

locations on the main bearing(s), gearbox, and generator should be spot faced, drilled and tapped for threaded attachment of the sensor to the machine.



Spot Face, Drill, & then Tap



MH117 Tool for Spot Facing & Drilling

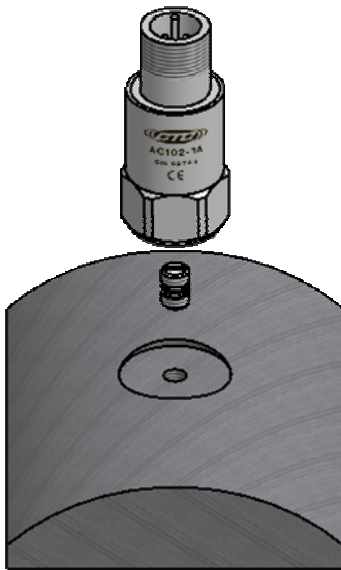

Mount Sensor on Machined Surface

Cables & Connectors

Wind turbines require rugged connectors rated to IP66. This level of ingress protection against dirt, water, and oil is ideal. Using the A2A Mil Style connector or the B2A seal tight boot will provide a rugged connection to the sensor that is protected from the environment. Teflon® jacketed cables or polyurethane cable can be used in conjunction with the connectors to form a complete cable and connection solution.



*A2A Connector with
CB102 Cable*



*B2A Connector with
CB111 Cable*



*A2A Connector with
CB103 Polyurethane
Cable*

Summary

Power generation is a critical need in today's world. Uptime is the primary concern, and to maintain power generation the machines need to be running. Main Bearing, Gear Box, and Generator failures are unacceptable for Wind Turbines. All of these items have significant replacement costs, weigh multiple tons, and sit on top of a tower 50 – 150 meters in the air.

Using permanently mounted accelerometers to monitor wind turbine vibration will provide early detection for:

- Bearing failures
- Gear wear and tear
- Blade vibration
- Electrical problems
- Unbalance
- Misalignment
- Looseness
- Resonance



CTC

VIBRATION ANALYSIS HARDWARE

www.ctconline.com

